

BIG SOSPENSIONE 1030
COD: 5500-LBN

Use:
inside, led
Installation:
Suspended
Fixing system:
Adjustable micrometric suspension system with steel cable L = 2100 mm
Body/structure:
Aluminium body
Coating:
Epoxy powder coating for inside use
Colour:
White
Glass/diffuser:
Polycarbonate bi-satinated diffuser
Cable gland:
Nylon 66 cable locks
Control gear:
Integrated LED diodes ballast, stabilized output current 1050mA dc

Voltage:	220-240V 50/60Hz
Beam angle :	Symmetric, double emission
Insulation class:	Insulation class 1
Weight:	21 kg
IP rating:	40
Glow wire:	[650 °C]
Lamp included:	Yes
Kind of led:	Power LED
Luminaire wattage:	283.5 W
Luminous flux:	28357.5 lm
Lamp/led rated life:	50000 hours h
Colour temperature:	4000
CRI:	80
Color constancy:	3 SDCM

Notes:
Direct light 187.5W 25100Lm
12400Lm

Indirect light 92W

Review board: 11-11-2015

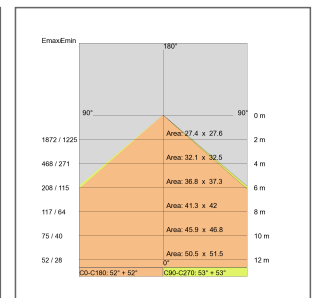
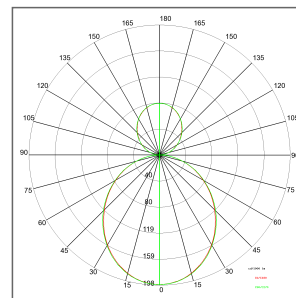

Lamp: 1 x LED 279.5 W 38120 lm



IP 40

A+



RG0

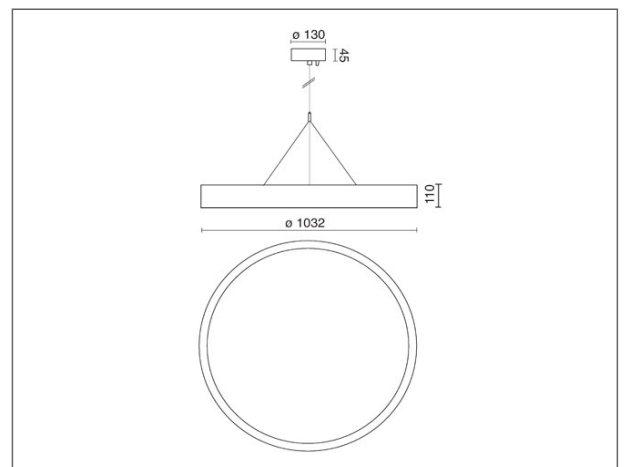

BIG SOSPENSIONE 1030
 COD: 5500-LBN

